



3GPP-TSG RAN WG2 #2

8-11 March 1999
Stockholm, Sweden

Tdoc RAN WG2 094/99

Agenda Item: 5.2

Source: Golden Bridge Technology, Inc.
On behalf of WP-CDMA Committee
(TIP1.5/TR46.1)

Title: An Overview of WP-CDMA Distinguishing Features

Document for: Discussion of WP-CDMA Distinguishing Features

Abstract: This contribution discusses the distinguishing features of WP-CDMA. The individual features shall be discussed in more detail in separate contributions. The proposed draft texts associated with each feature are submitted as separate contributions

The WP-CDMA distinguishing features are as follows:

1. Uplink Common Packet Channel
2. Downlink Common Control Channel
3. Intra-frequency Hard Handover
4. Quick Handover
5. WP-CDMA Common Control Physical Channel (modified Ad-Hoc S)
6. Multi-code Option
7. Higher APC Rate
8. Removal of Link Maintenance Channel

In this contribution each feature is briefly discussed. The WP-CDMA is a multimedia-centric, data-centric proposal, which is optimized for IP Access through the introduction of uplink common packet channel. Furthermore, WP-CDMA offers lossless hard handover, and optimum bandwidth allocation to synchronous and asynchronous users. WP-CDMA offers first system and packet acquisition. And finally, circuit-switching and packet switching transfer modes coexist on the WP-CDMA air interface.



Dr. Kourosch Parsa
VP Systems Engineering, Golden Bridge Technology, Inc.
Chair: Baseband CAI WGII TR46.1
Voice: 732 728-9627

Email: kpgbt@aol.com

3GPP-TSG RAN WG2 # 2
Stockholm, Sweden
March 8-11, 1999



WP-CDMA RTT

- Product of harmonization of two US proposals
 - WCDMA N/A (T1P1)
 - WIMS W-CDMA (TR46.1)
- Compatible with ETSI UTRA proposal
- Identifies 8 additional features, all associated with improved Packet Data Performance



WP-CDMA ADDITIONS TO UTRA

- Hard Handover for Packets
- Fast TPC for Packets
- Quick Handover
- New Channels:
 - Common Control Channel in DL
 - Common Packet Channel in UL
- Multi-code option
- New Structure for Primary Common Control Physical Channel (modified Ad-Hoc S)
- Removal of the Link Maintenance Channel



Recommended Approach for Integration of WP-CDMA features will avoid schedule delays

- Continue within framework of current 3GPP baseline documents
- Evaluate and refine WP-CDMA features within appropriate WGs and Ad Hoc



Source Material

- Full RTT is available <http://www.itu.int/imt/2-radio-dev/proposals/31-9-98/index.html>
- Exerpts of sections that differ from ETSI UTRA are available RAN WG2#2 Tdoc 096/99, 098/99, 100/99, 102/99 and RAN WG1#2 99/025

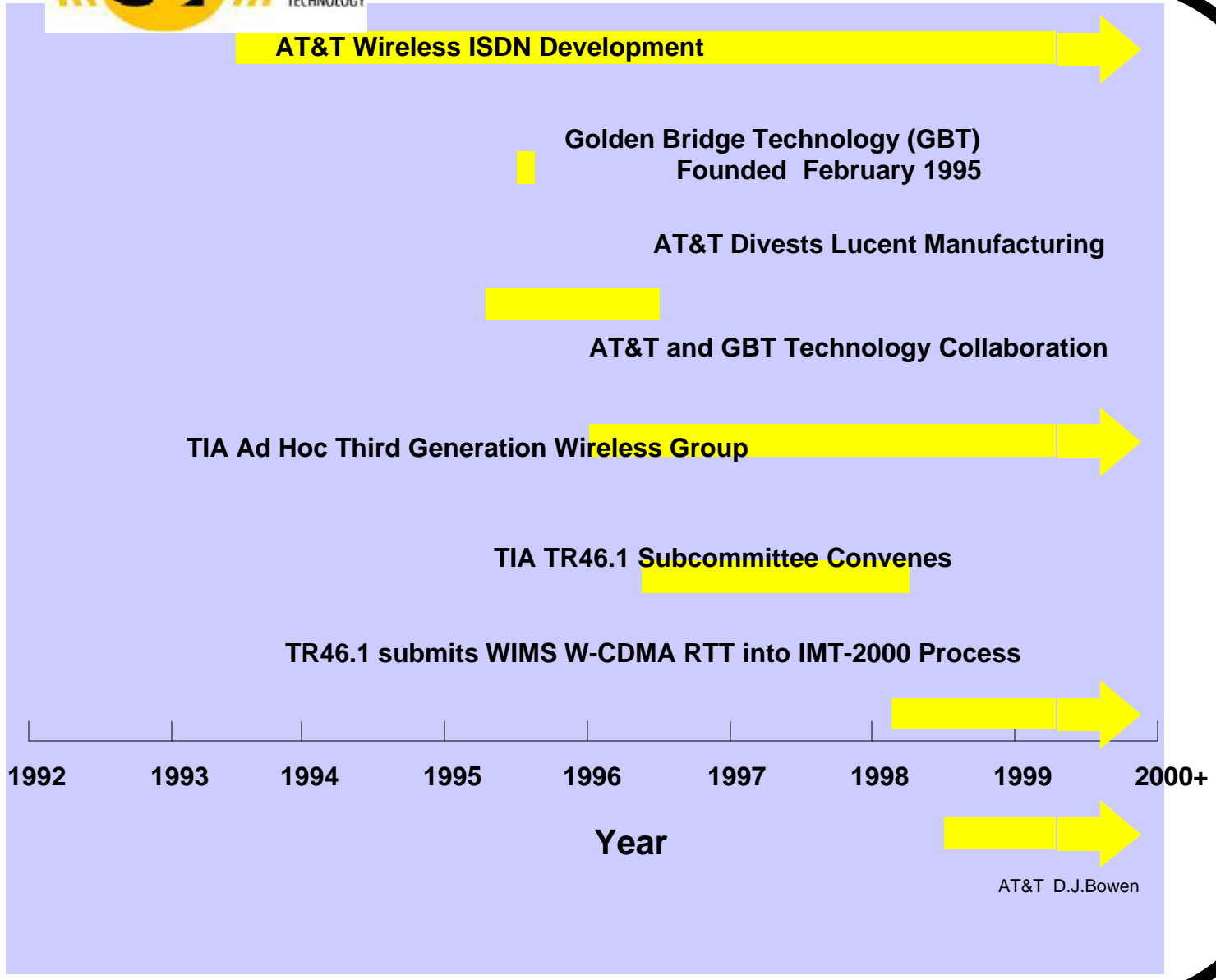



WP-CDMA Participants

Regular participants in WP-CDMA meetings include:



•AT&T Laboratories



•Ericsson



•Golden Bridge Technologies (GBT)



•Hughes Network Systems (HNS)



InterDigital Communications Corporation (IDC)



•Lucent Technologies



•Nokia



•Northern Telecom (Nortel)



•OKI Telecom

AT&T D.J.Bowen



WP-CDMA Participants Continued

- Epson
- Motorola
- Siemens
- Bell South Mobile
- Omnipoint

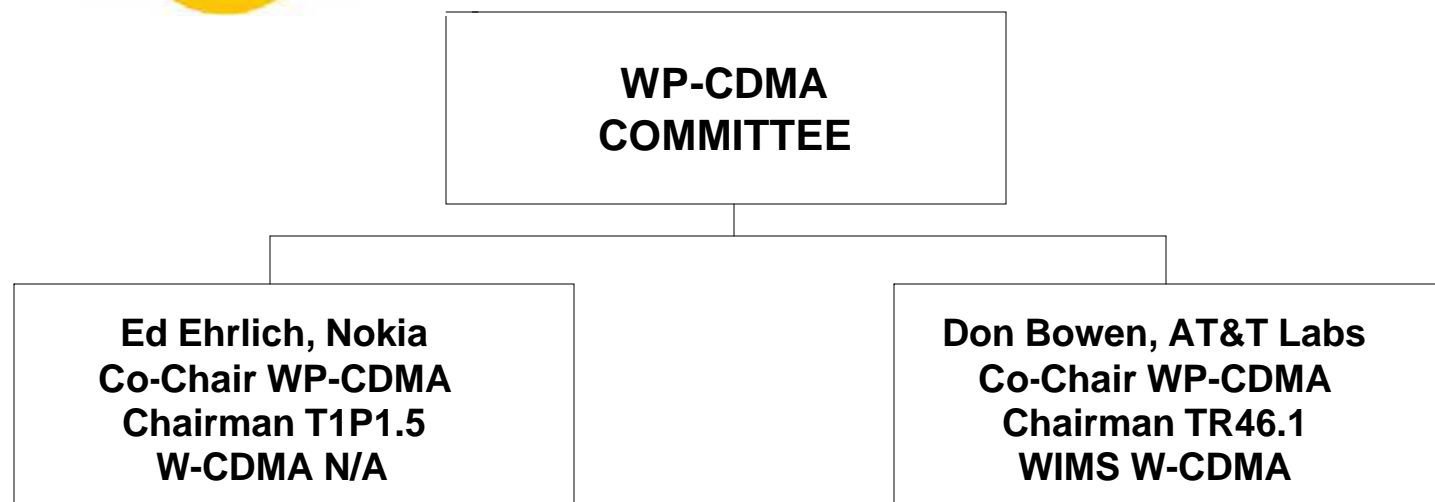

- Convergence activities in the month of October
- Converged RTT called WP-CDMA was produced in December 1998 and was submitted to ITU on January 8, 1999.
- WIMS W-CDMA abandoned common header on the downlink and constant processing gain. So, the WP-CDMA RTT became an UTRA-variant proposal with seven unique features.
- The most important feature of the WP-CDMA is the Reverse Link Common Packet Channel.



Summary of WP-CDMA Key Technical Parameters

Key Parameters	WIMS W-CDMA (Oct. 1, 1998)	WP-CDMA
Multiple Access	DS-SS	Same
Band Width	5, 10, 20 MHz	Same
Chip Rate	4.096, 8.192, 16.384 Mcps	Same
Carrier Spacing	Flexible with 200kHz carrier raster (30kHz raster under study)	Flexible with 200kHz carrier raster. (30kHz carrier raster in regions where required)
Inter BS timing	Asynchronous (Sync. Possible)	Same
Cell Search Scheme	3 step code acquisition algorithm based on common header	3 step code acquisition algorithm based on modified Ad Hoc – S agreements on pilots.
Frame Length	10ms	Same
Variable Spreading Factor (VSF) (FOR 5 MHz SPREAD BANDWIDTH) What is VSF for user information rate 1 (8 kbps) and user information rate 2 (2.048 Mbps)	64 & 64	256 & 4 Variable spreading factor. VSF range of 4 to 256 used in conjunction with variable number of multi-codes.
IntracARRIER HO	Soft Handover /Hard Handover 'quick' Hard Handover	SHO/HHo
InterCARRIER HO	HHO with compressed transmission	Same



Summary of WP-CDMA Key Technical Parameters

DL	Channelization Codes	Orthogonal modified quadratic residue codes – length of 64 chips	Orthogonal variable spreading codes
DL	Data mod.	QPSK	Same
	Spreading modulation	QPSK	BPSK
	Channel code length	1 symbol length	Same
	Scrambling code length	10 ms	Same
	Pilot structure	Common pilot symbols	Common time multiplexed and dedicated pilot on Ad Hoc – S recommendations
		Time multiplexed.	Same
	Detection	Pilot symbol based coherent	Same
	Power control	Closed-loop based on dedicated channel SIR – 1.6kHz Higher rates under investigation	Closed-loop based on dedicated channel SIR –1.6 kHz. Higher rates under investigation
Variable rate accommodation	Orthogonal multi-code (MC) + DTX	Orthogonal variable spreading factor + multi-code (MC)+DTX.	



Summary of WP-CDMA Key Technical Parameters

UL	Data mod.	QPSK	BPSK
	Spreading mod.	QPSK	Same
	Channel code	1 symbol length	Same
	Scrambling code length	10 ms	Same
	Pilot structure	Time and code multiplexed	IQ/code multiplexed
	Detection	Pilot Symbol Based coherent	Same
	Power control	Closed-loop (initial, RACH) Closed-loop on Common Packet Channel	Open Loop (initial RACH) Closed Loop on Common Packet Channel
	Variable rate concept	Multi-Code	VSF+ Rate Matching Multi-code
Channel Coding	Convolutional codes, Turbo codes under study		Convolutional codes, RS Codes, Turbo codes under study.
Interleaving periods	10/20/40/80 ms		Same
Rate Detection	Explicit Rate information	Explicit rate information or blind rate detection	
Random Access mechanism	Preamble and variable message length		New ramp-up function to improve throughput delay performance
Power control steps	1 dB		0.25 – 1.5dB
Super Frame Length	720 ms		Same



WP-CDMA Distinguishing Features

1. Uplink Common Packet Channel (All Rates)

- Common Packet Channel will transport all data rates up to and including 2.048 Mbps.
- Constant Power Level Preamble with 16 possible sequences
- Closed Loop Power Control, Preamble Ramp-up mechanism
- Fast L1 ACK mechanism (within 250 micro-seconds)
- Collision Detection with Low Feedback Delay (2 ms)
- Downlink Common Power Control Structure

2. Common Control Channel in the Downlink

3. Intra-frequency Hard Handover

4. Quick Handover

5. Structure of the WP-CDMA CCPCH

(Common Control Physical Channel)

- TM Common Pilot for coherent demodulation
- Adjustable Power SCH1 And SCH2 for faster initial cell search

6. Multi-code Option for Higher Rates

- The relationship between the Variable Spreading Factor and number of multi-codes is the subject of further study

7. Higher APC Rates

8. Removal of Link Maintenance Channel



WP-CDMA Distinguishing Features

Feature 1: Uplink Common Packet Channel (All Rates)

- Common Packet Channel will transport all data rates up to and including 2.048 Mbps.
- Constant Power Level Preamble with 16 possible sequences
- Closed Loop Power Control, Preamble Ramp-up mechanism
- Fast L1 ACK mechanism (within 250 micro-seconds)
- Collision Detection with Low Feedback Delay (2 ms)
- Downlink Common Control Channel Structure



WP-CDMA Common Packet Channel Uplink

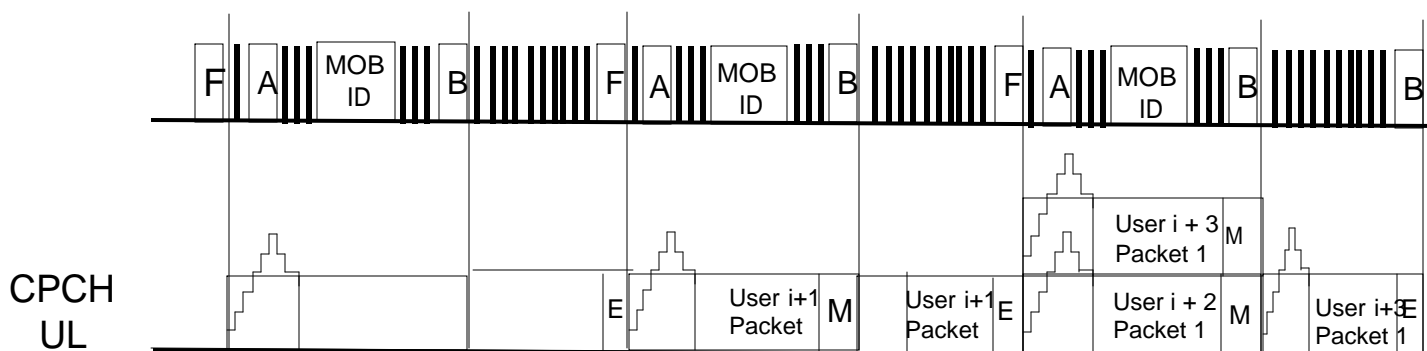

- F = Free
- A = ACK
- B = Busy
- Mob ID = Temp ID for Collision Detection
- E = End
- M = More



Feature 2: DL Common Control Slot Structure

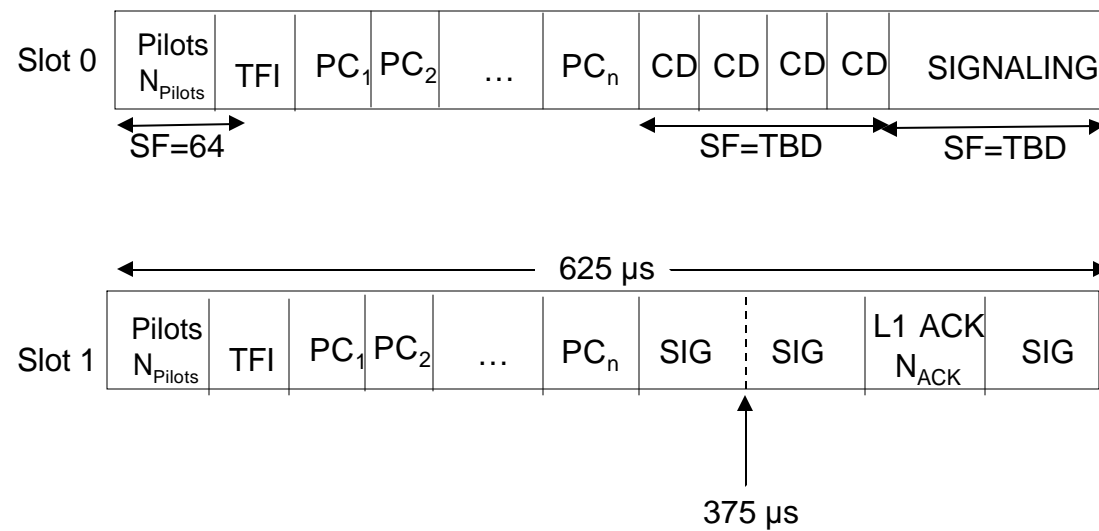



Feature 3: Hard Handover

Hard Handover Physical Layer Procedure

- **The gain of Soft Handover over Hard Handover diminishes as B.W. increases.**
- **Soft Handover is critical for N-CDMA, but not W-CDMA**
- **The order of diversity is much higher in W-CDMA as compared to N-CDMA, so the gain of Soft Handover over Hard Handover is much less.**
- **Soft Handover decreases capacity in the DL direction**



Hard Handover Proposal

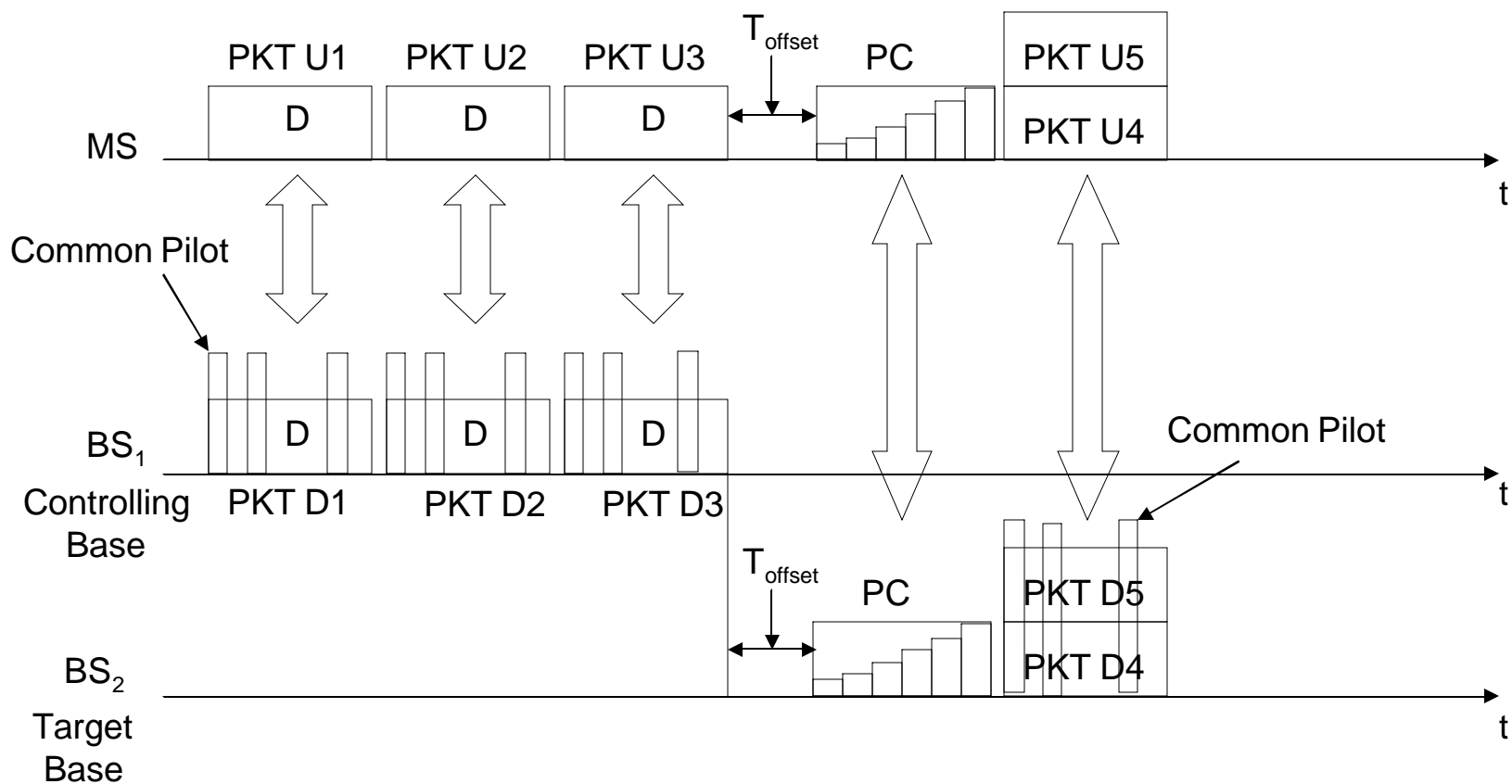

T_{offset} = time offset between BS₁ and BS₂
 UL and DL Frames are assumed to be time-aligned

Packets = 10 ms Frames



Feature-4: Quick Handover

- Significantly lowers the call drop rate
- Combats corner effect
- Adapts to rapidly changing multipath profile
- Improves order of diversity



Lowest call dropping

- Fast link re-acquisition (call dropping)
- Fast adaptation to rapidly changing multipath profile (call dropping)

Link Re-acquisition

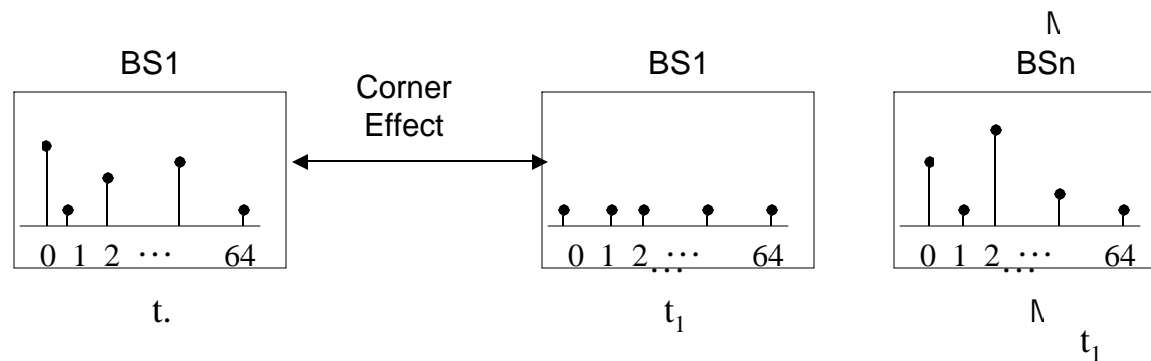
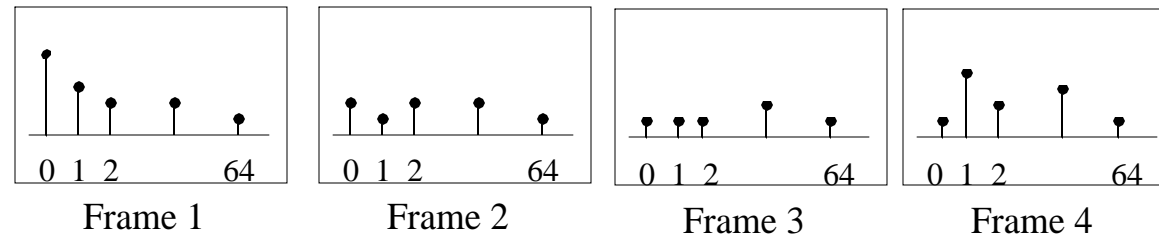



Feature 5: Structure of the WP-CDMA CCPH Common Control Physical Channel

The WP-CDMA CCPCH is based upon the Ad-Hoc S parameterized Perch channel with the following modifications:

- **The primary SCH and secondary SCH are multiplexed onto the I and Q channel respectively.**
- **The power of the primarySCH is controlled by parameter P3. This is the unmodulated primary sync code as found in WCDMA/NA, UTRA, and ARIB.**
- **The power of the secondarySCH is controlled by parameter P4. This is the secondary sync code scheme as specified in UTRA.**
- **The Common Pilot is Time Multiplexed with Data.**
- **The dedicated pilot is supported with the following parameters: C2, L2 and P2. The dedicated pilot is time multiplexed with the Traffic Channels.**



Structure of the WP-CDMA CCPCH.

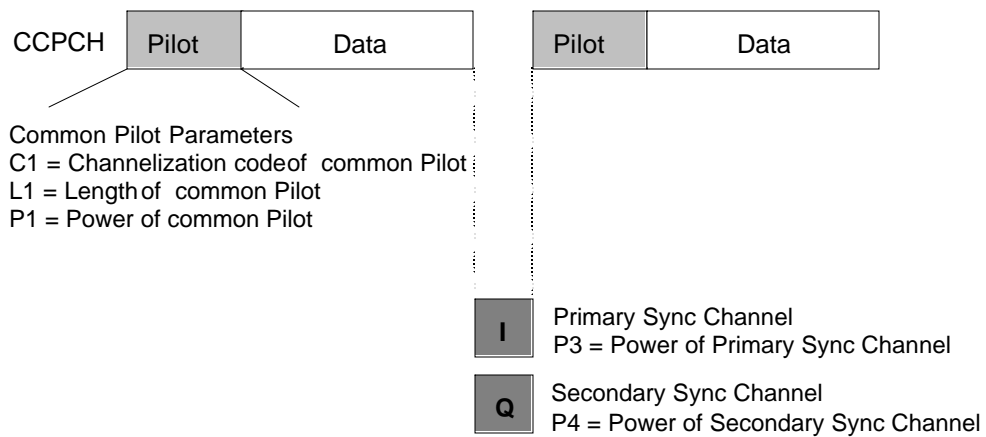



Conclusion

- WP-CDMA is a data-centric, multi-media-centric, Radio Access Technology
- Common Packet Channel in the UL and DL direction facilitates packet switching transfer mode over the Air Interface
- Coexistence of circuit Switching and Packet Switching Capabilities on the Air Interface
- WP-CDMA is optimized for Packet Data Service and IP Access.
- WP-CDMA has fast system acquisition and fast packet acquisition.
- WP-CDMA offers fast lossless hard handover and quick handover minimizing call drop rate
- WP-CDMA offers optimum bandwidth allocation method

