



# Overview of Data Rate Control in UMTS

---

Dr. Kouros Parsa  
December 30, 2005

# UMTS family bearer speed comparison

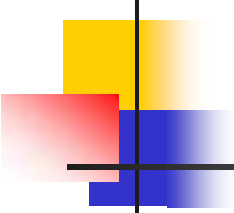

Technology	Maximum theoretical rate (DL)	Maximum theoretical rate (UL)	Estimated launch dates	Estimated throughput/ User
GPRS	170 kbps	170/4 kbps	-	20-40 kbps
EDGE	470 kbps	470 kbps/4	-	100-130 kbps
UMTS Release 99	2 Mbps	384 kbps	2004	220-330 kbps
UMTS Release 5 / HSDPA	14.4 Mbps	384 kbps	2005	550-1100 kbps
UMTS Release 7/ HSUPA	14.4 Mbps	5.76 Mbps	2007	TBD
UMTS Release 8/ 3.9G	200 Mbps	100 Mbps	2010	TBD

# UTRAN Architecture

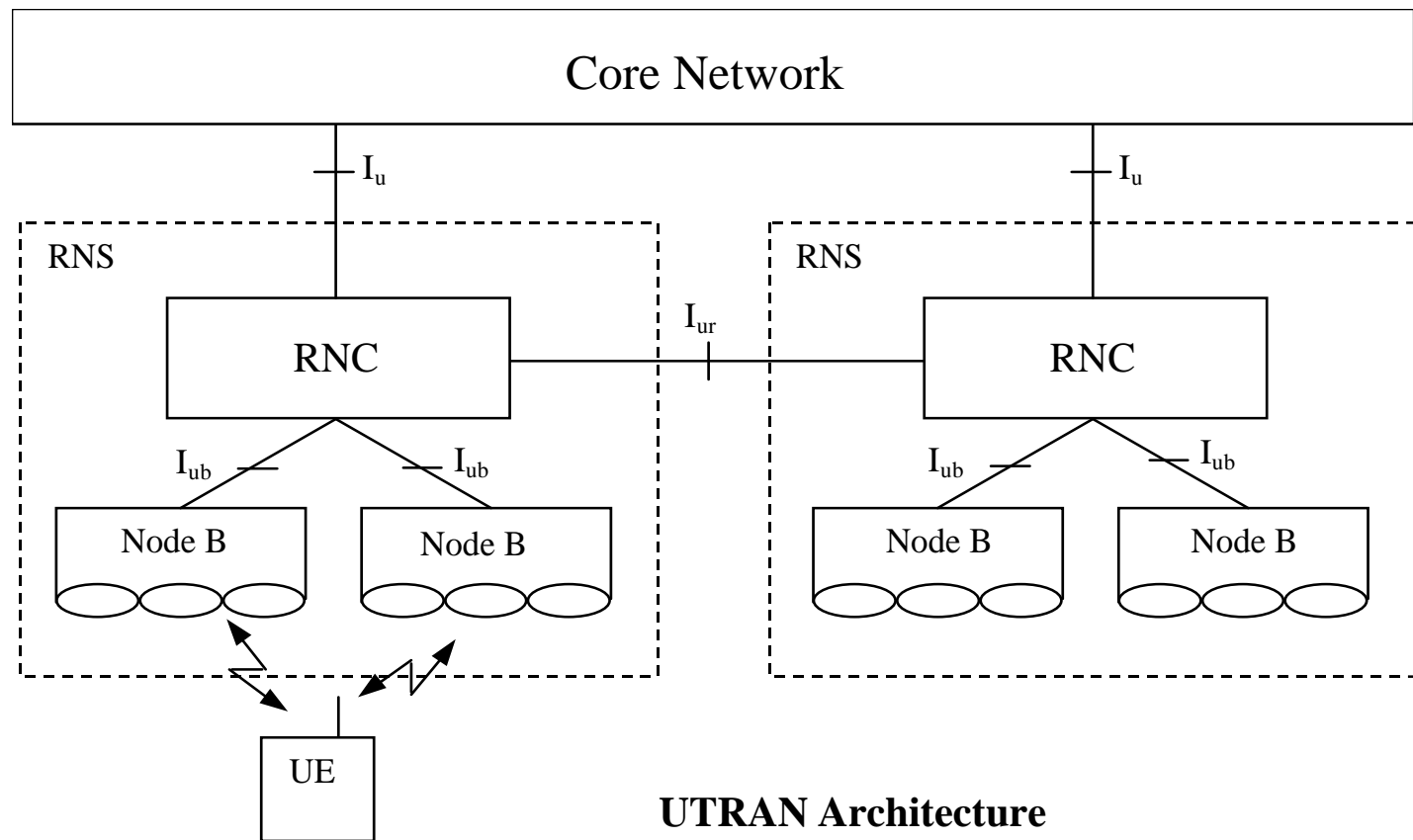

# Frame structure for uplink DPDCH/DPCCH

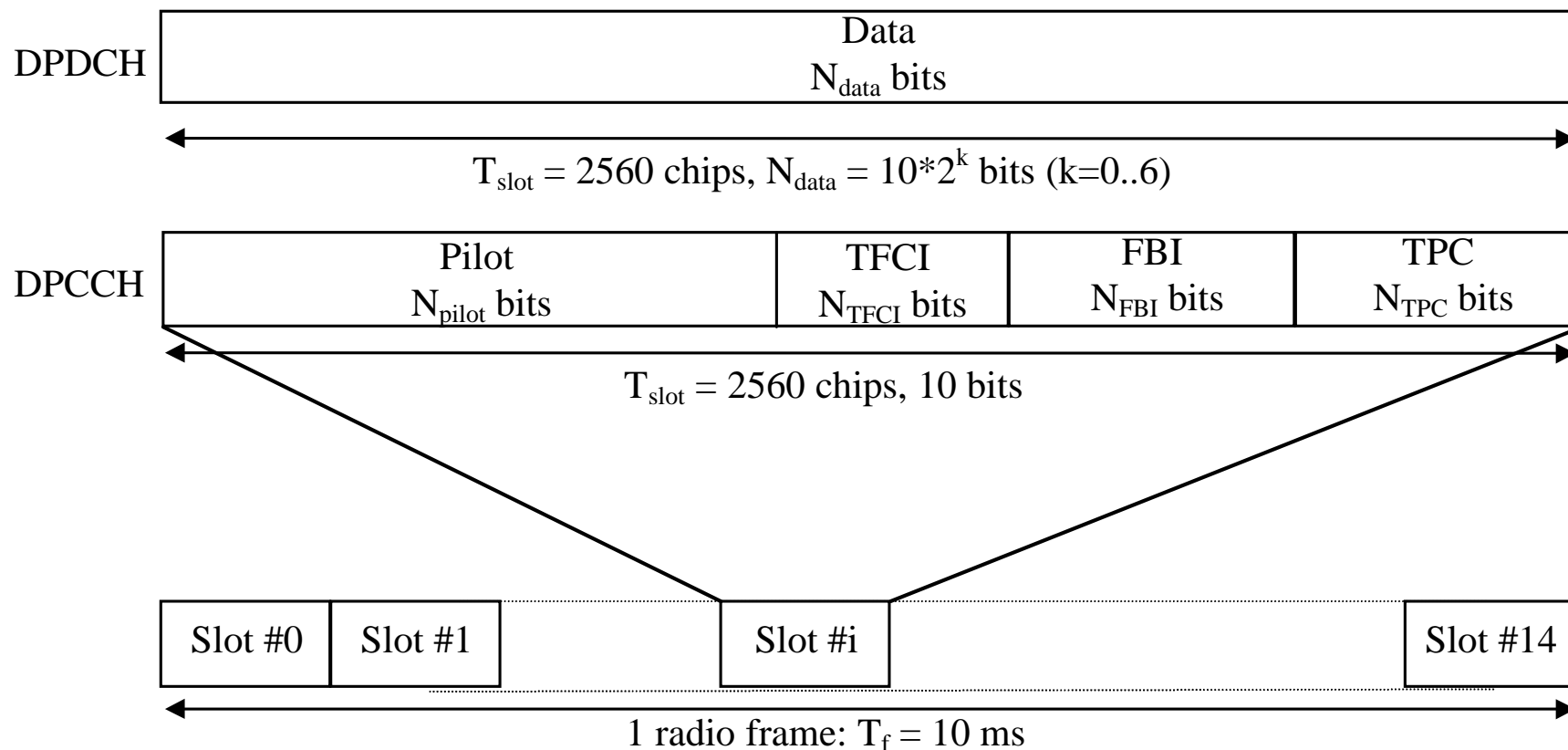

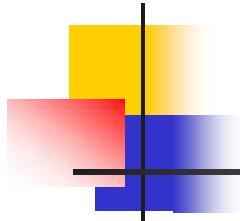

# Spreading Factor

---

- The parameter  $k$  in figure 1 determines the number of bits per uplink DPDCH slot. It is related to the spreading factor SF of the DPDCH as  $SF = 256/2^k$ . The DPDCH spreading factor may range from 256 down to 4. The spreading factor of the uplink DPCCH is always equal to 256, i.e. there are 10 bits per uplink DPCCH slot.

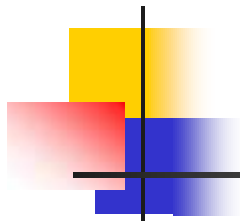

# Slot Formats

---

- The exact number of bits of the uplink DPDCH and the different uplink DPCCH fields ( $N_{\text{pilot}}$ ,  $N_{\text{TFCI}}$ ,  $N_{\text{FBI}}$ , and  $N_{\text{TPC}}$ ) are provided in 25.211. What slot format to use is configured by higher layers and can also be reconfigured by higher layers.

# Frame structure for downlink DPCH

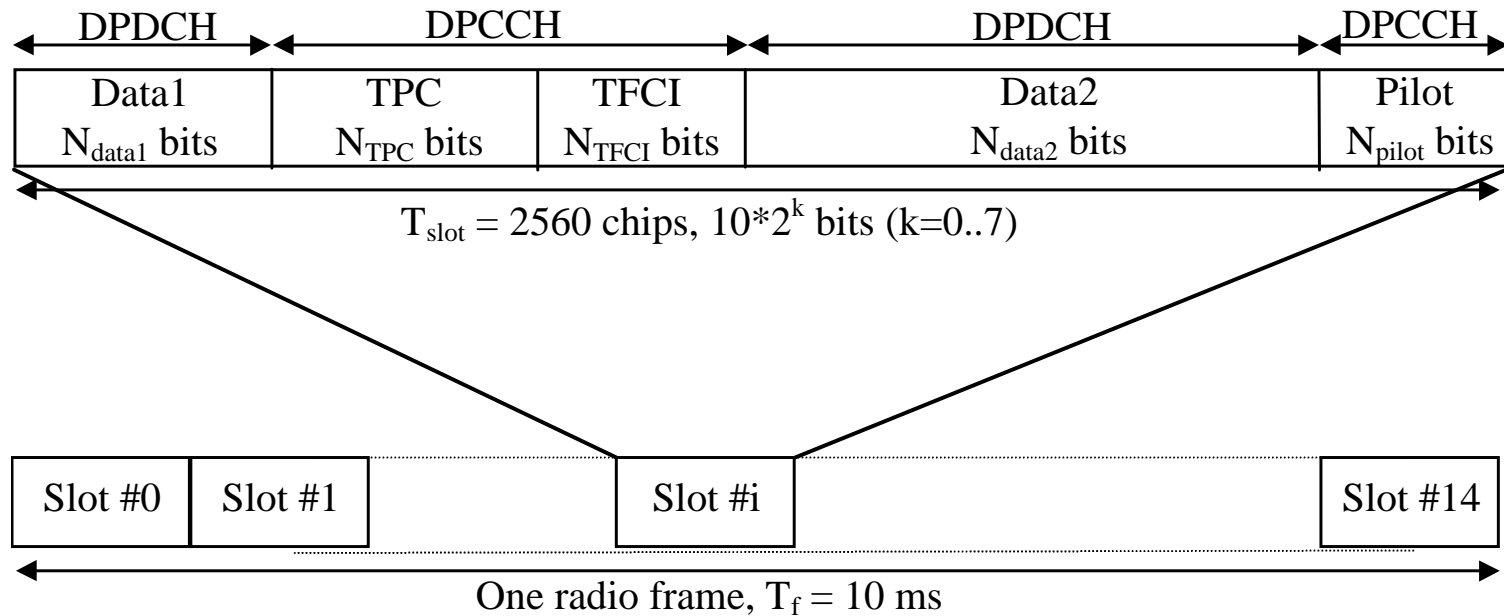

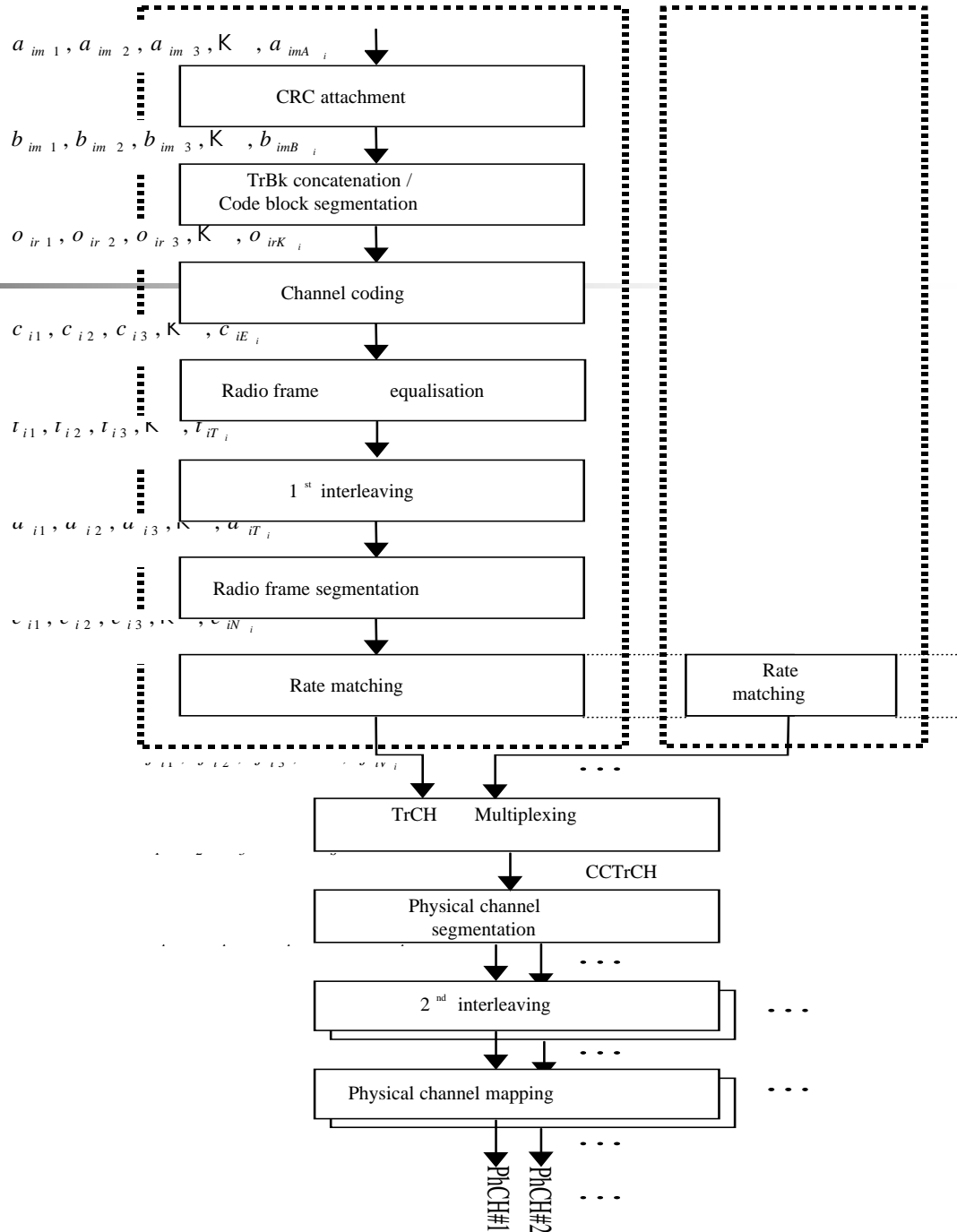
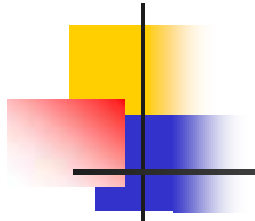

Transport channel multiplexing structure for uplink:

Source: 25.212



# Transport channel multiplexing structure for downlink:

Source: 25.212

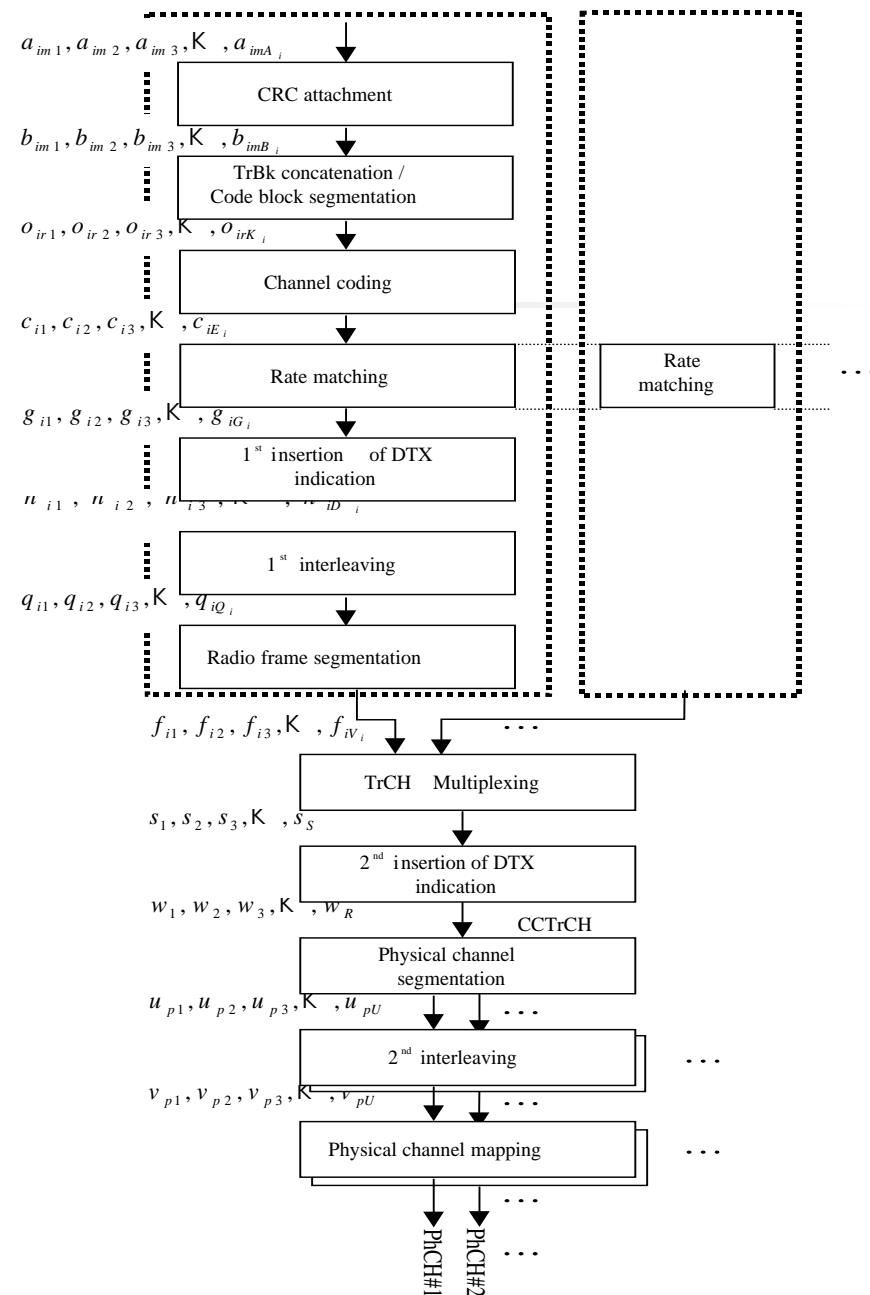

## Channel coding and multiplexing example for DTCH and DCCH: Channel coding example for the UL 64 kbps channel

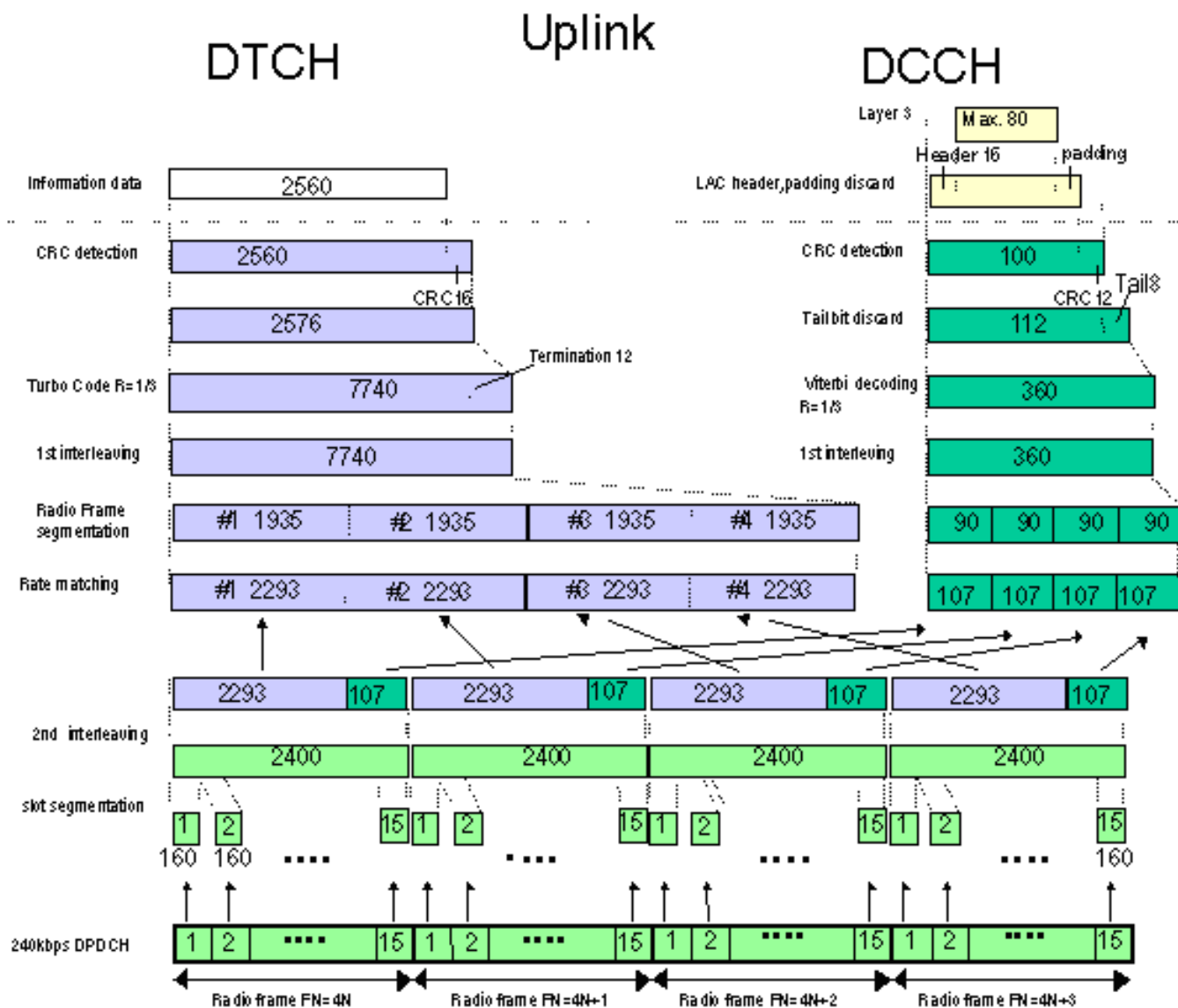
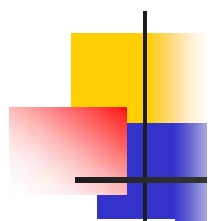

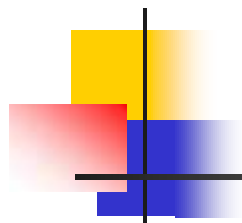

## How is data rate signaled?

---

- For each radio frame the UE and the network indicate the current data rate (in uplink and downlink respectively) using the transport format combination indicator (TFCI).

# Transport Block size and Data Rate



---

- Continuous DTCH data stream is segmented into transport blocks on RLC and mapped on a DCH transport channel on MAC. The transport block size is naturally implied by the data rate.

# MAC function in data rate Selection



---

- Selection of appropriate Transport Format for each Transport Channel depending on instantaneous source rate;

# Physical layer processing of transport blocks



---

- The physical layer operates exactly according to the L1 radio frame timing. A transport block is defined as the data accepted by the physical layer to be jointly CRC protected. The transmission block timing is then tied exactly to the TTI timing, e.g. every transmission block is generated precisely every TTI.
- A UE can set up multiple transport channels simultaneously, each having own transport characteristics (e.g. offering different error correction capability). Each transport channel can be used for information stream transfer of one radio bearer or for layer 2 and higher layer signaling messages.

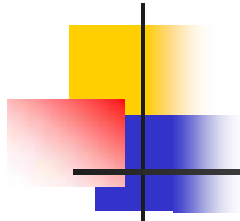

# Transport Format

---

- To each transport channel, there is an associated Transport Format (for transport channels with a fixed or slow changing rate) or an associated Transport Format Set (for transport channels with fast changing rate). A Transport Format is defined as a combination of encodings, interleaving, bit rate and mapping onto physical channels. A Transport Format Set is a set of Transport Formats. E.g., a variable rate DCH has a Transport Format Set (one Transport Format for each rate), whereas a fixed rate DCH has a single Transport Format.

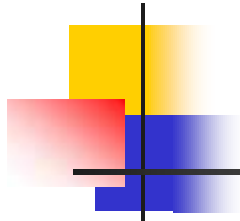

# Transport Format

- This is defined as a format offered by L1 to MAC (and vice versa) for the delivery of a Transport Block Set during a Transmission Time Interval on a Transport Channel. The Transport Format constitutes of two parts – one dynamic part and one semi-static part.
  - Attributes of the dynamic part are:
    - - Transport Block Size;
    - - Transport Block Set Size;
    - - Transmission Time Interval
  - Attributes of the semi-static part are:
    - - Transmission Time Interval (mandatory for FDD)
      - - error protection scheme to apply;
      - - type of error protection, turbo code, convolutional code or no channel coding (TDD only);
      - - coding rate;
    - - static rate matching parameter;
    - - size of CRC.

Dynamic part: {320 bits, 640 bits}, Semi-static part: {10ms, convolutional coding only, static rate matching parameter = 1}.

An empty Transport Format is defined as a Transport Format that has Block Set Size equal to zero.

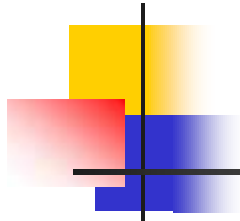

# Transport Format Set

---

- This is defined as the set of Transport Formats associated to a Transport Channel.
- The semi-static parts of all Transport Formats are the same within a Transport Format Set.
- Effectively the Transport Block Size and Transport Block Set Size form the instantaneous bit rate on the Transport Channel. Variable bit rate on a Transport Channel may, depending on the type of service, which is mapped onto the transport channel, be achieved by changing between each Transmission Time Interval one of the following:
  - The Transport Block Set Size only (not applicable for HS-DSCH);
  - both the Transport Block Size and the Transport Block Set Size

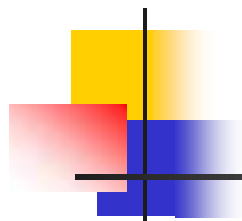

# Transport Format Set Examples

---

- Example 1 for DCHs:
  - - dynamic part: {20 bits, 20 bits}; {40 bits, 40 bits}; {80 bits, 80 bits}; {160 bits, 160 bits}.
  - - Semi-static part: {10ms, Convolutional coding only, static rate matching parameter = 1}
- Example 2 for DCHs:
  - - dynamic part: {320 bits, 320 bits}; {320 bits, 640 bits}; {320 bits, 1 280 bits}.
  - - Semi-static part: {10ms, Convolutional coding only, static rate matching parameter = 2}.
- Example 3 for HS-DSCH:
  - - dynamic part: {320 bits, 320 bits, Redundancy version 1, QPSK}; {640, 640, Redundancy version 1, QPSK}; {1280, 1280, Redundancy version 2, 16QAM}. Static = ?



# Transport Format Indicator (TFI)

---

- The TFI is a label for a specific transport format within a transport format set. It is used in the inter-layer communication between MAC and L1 each time a transport block set is exchanged between the two layers on a transport channel.
- Transport Format Combination Indicator (TFCI): This is a representation of the current Transport Format Combination.
- There is a one-to-one correspondence between a certain value of the TFCI and a certain Transport Format Combination. The TFCI is used in order to inform the receiving side of the currently valid Transport Format Combination, and hence how to decode, de-multiplex and deliver the received data on the appropriate Transport Channels. The TFCI is not used for the HS-DSCH.

# Transport channel parameters in uplink



---

- This parameter dictates the maximum data rate allocated to each mobile.
- This parameter is defined as the Maximum sum of number of bits of all transport blocks being transmitted at an arbitrary time instant:
  - Examples: 640, 1280, 2560, 3840, 5120, 6400, 7680, 8960, 10240, 20480, 40960, 81920, 163840

# How does variable data rate work?

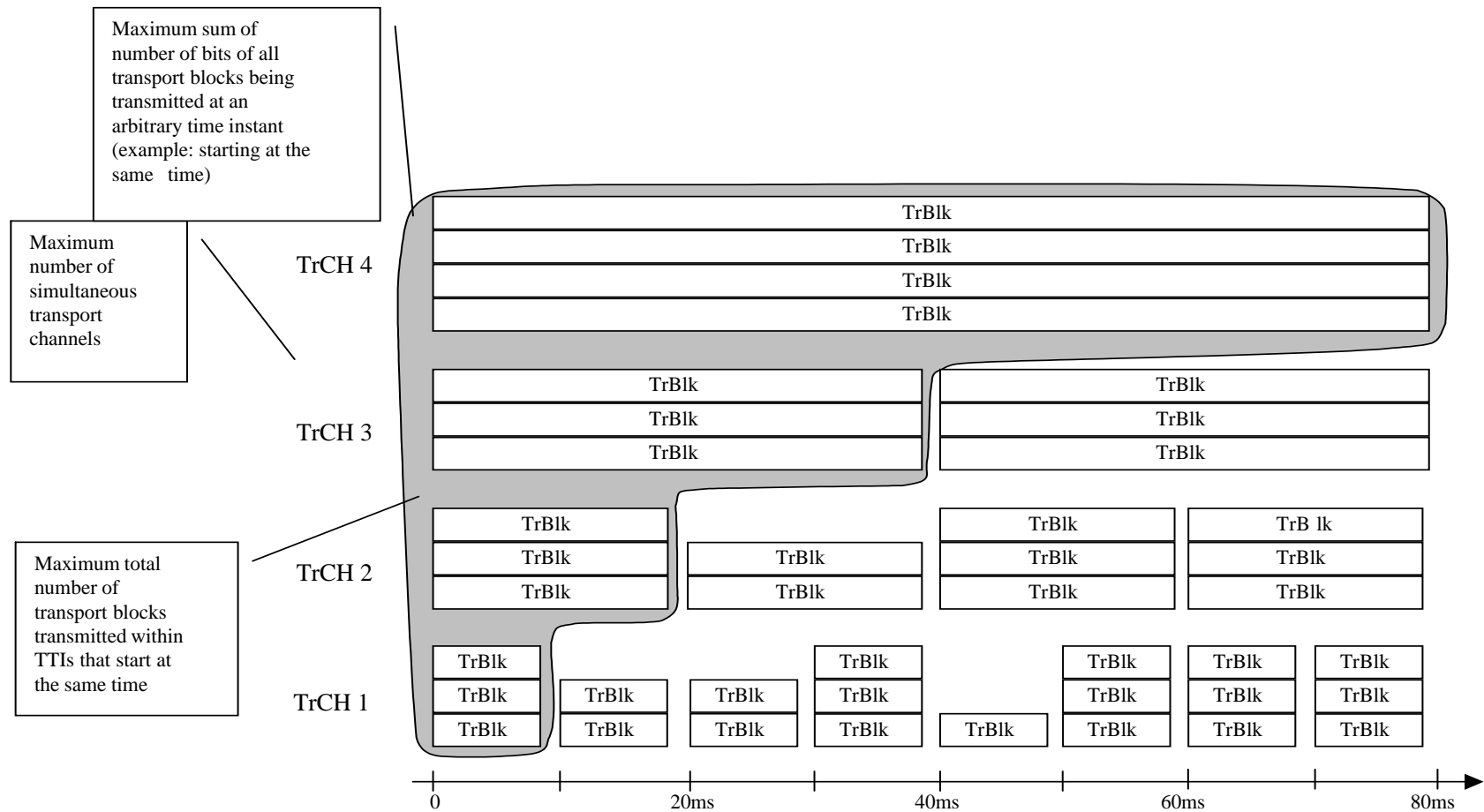
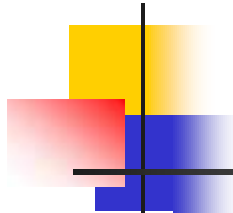



# Conclusion

---

- The key to understand how data rate is signaled in UMTS is related to understanding of TFCI.