

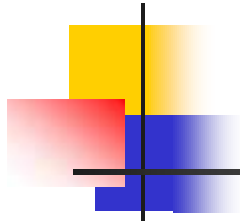

Overview of OFDMA

Dr. Kourosh Parsa

December 30th, 2006



OFDM definition

- OFDM is a communications technique that divides the spectrum into a number of equally spaced tones, and carries a portion of a user's information on each tone. A tone can be thought of as a frequency.
- The OFDM tones are orthogonal, which means that the individual tones do not interfere with each other.

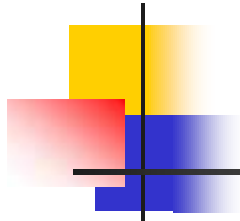

OFDM Basics

- Frequency division multiplexing (FDM) is a technology that transmits multiple signals simultaneously over a single transmission path, such as a cable or wireless system. Each signal travels within its own unique frequency range (carrier), which is modulated by the data (text, voice, video, etc.).

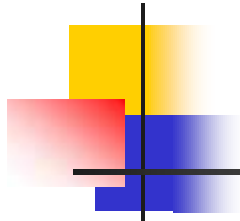

OFDM

- OFDM technique distributes the data over a large number of carriers that are spaced apart at precise frequencies. This spacing provides the "orthogonality" in this technique which prevents the demodulators from seeing frequencies other than their own.

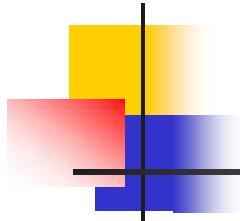

OFDM Basics

- OFDM is sometimes called multi-carrier or discrete multi-tone modulation. It is the modulation technique used for digital TV in Europe, Japan and Australia.
- The benefits of OFDM are high spectral efficiency, resiliency to RF interference, and lower multi-path distortion. Since multiple versions of the signal interfere with each other (inter symbol interference (ISI)) it becomes very hard to extract the original information.

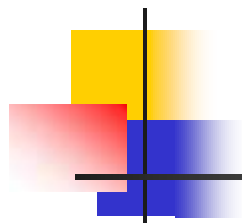

Basics of OFDM modulation

- OFDM is claimed to suite high bit rate transmission in downlink, as it is well known to offer good robustness to multipath propagation with a relatively low implementation complexity (FFT).

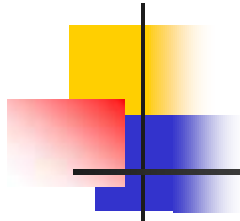

OFDMA standards

- This technique has been selected for broadcasting standards (DAB, DVB-T) as well as for high data rate radio LANs such as HIPERLAN/2 and IEEE 802.11a.
- OFDMA is also a major part of LTE, UMB and WiMAX including 802.16m.

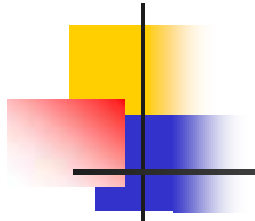

OFDM in dispersive environment

- OFDM is very efficient in time and frequency dispersive environments e.g. in environments suffering from multipath propagation and Doppler effect, especially when used with channel coding and interleaving (Coded OFDM).

Figure 1: OFDM symbol representation: Source: R1-02-1229 / Wavecome

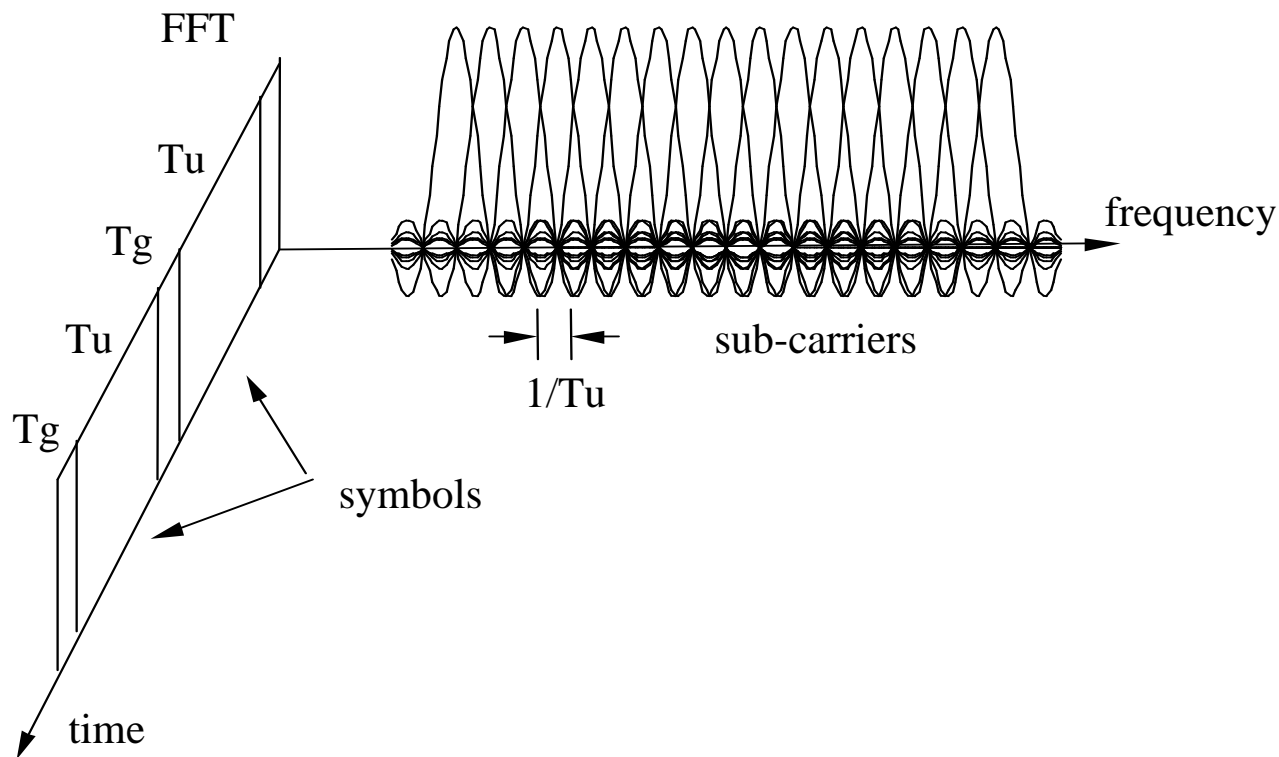

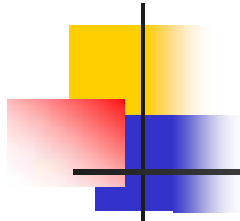

OFDM

- The OFDM symbol is presented on Figure 1, where T_u = useful symbol duration and T_g the guard interval.
- OFDM principle is to split the high bit rate information to be transmitted over a large number of carriers, in such a way that the modulated symbols will be much longer than the delay spread i.e. in order to combat ISI. This makes the modulation intrinsically robust to multipath.

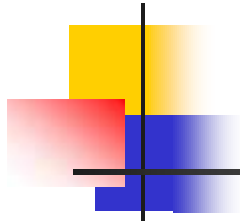

OFDM and multi-path

- To combat multipath effect, a guard interval is appended to each OFDM symbol. It is selected long enough to absorb all the intersymbol interferences. The channel becomes flat on each sub-carriers. However, frequency selectivity still exists on the overall signal bandwidth. To handle it, coding and interleaving are used in combination with OFDM modulation.

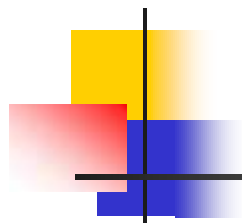

Orthogonality in OFDM

- Orthogonality is guaranteed between all overlapping sub-carriers composing the frequency multiplex, and between consecutive OFDM symbols. This multi-carrier modulation is spectral efficient.

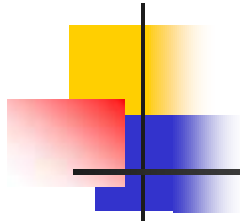

OFDM and fading

- Applying these techniques to OFDM leads to averaging local fading over the whole signal bandwidth and over the time interleaving depth. Frequency selectivity is then turned into an advantage, which corresponds to frequency diversity.

Principle of OFDM transmission chain

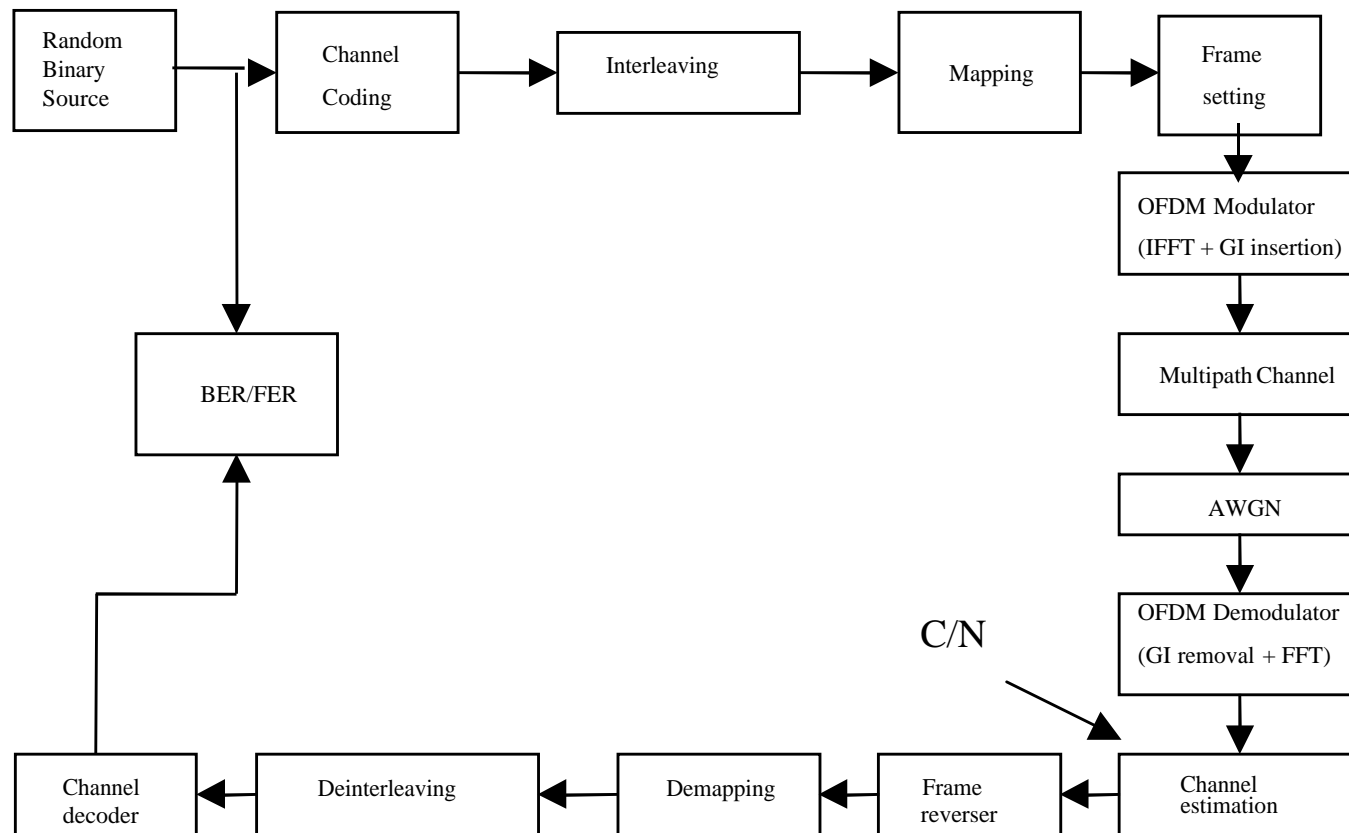

OFDM principles: *multi-carrier block identification*

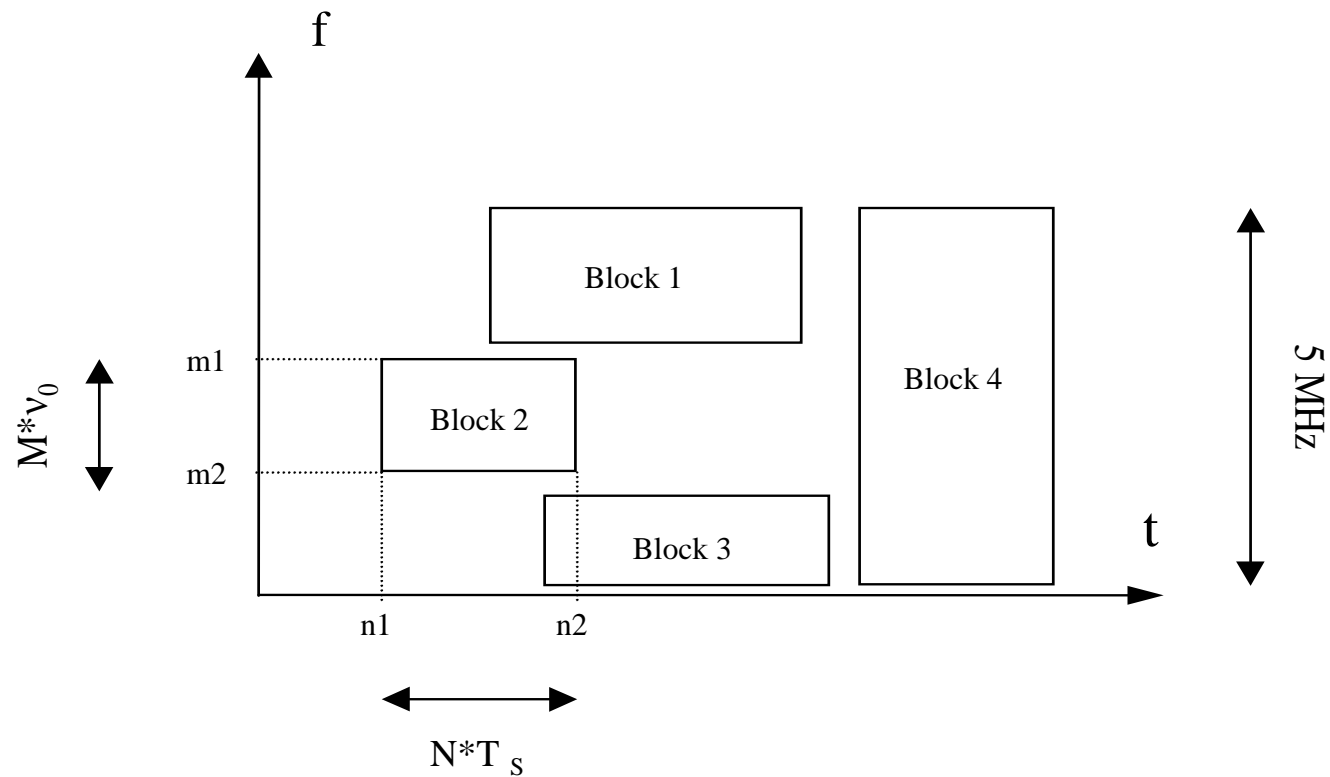

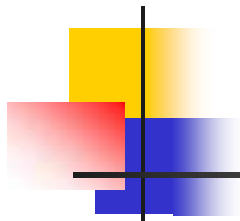

OFDM Basics

- OFDM access scheme is represented on the previous slide (where ν_0 is the intercarrier spacing and T_s the total symbol duration i.e. $T_s = T_u + T_g$).
- In the frequency domain, frequency hopping can be used to perform Dynamic Channel Allocation. This technique also provides a global capacity improvement (inter-cell-interference averaging).



Basic OFDM parameters

An example in WiMAX

- Bandwidth = $B = 1/T_s$
 - Example = 10 Mhz
- Number of Sub-carriers = $L =$ size of the FFT/IFFT
 - Example = 1024
- Guard Fraction = $G =$ %of CP
 - Typically 1/8

Basic OFDM parameters

An example in WiMAX

- Data sub-carriers = L_d
 - Example = 768
- Sample time = $T_s = 1/B$
 - Example = 1 usec
- Guard Symbols = $N_g = G_L$
 - Example = 128
- Guard Time = $T_g = T_s \times N_g$
 - Example = 12.8 usec
- OFDM Symbol Time
 - $T = T_s (L + N_g) = 115.2$ usec
- Sub-carrier Bandwidth = $B_{sc} = B/L$
 - Example = 9.76 KHz



Newly emerged and emerging OFDMA technologies

- Existing OFDMA-based cellular technologies:
 - WiMAX: 802.16e
- Emerging OFDMA-based technologies:
 - 802.16m [WiMAX2]
 - LTE
 - UMB

Comparison Table

	WiMAX Release 1	LTE	UMB
Duplex method	TDD FDD	TDD FDD	FDD Half duplex
Coherence time // Doppler spread@ 2.5 GHz $FD = v \cdot f_c / c$	1.2 mph, 4.6 Hz [$T_c = 200$ ms] 27 mph, 104 Hz [$T_c = 10$ ms] 60 mph, 231 Hz [$T_c = 4$ ms]	FFS	FFS
$B_c = 1 / (5 \cdot \tau_{rms})$ Coherence bandwidth // rms delay spread Assume 1 microseconds	200KHz	200KHz	200KHz
Carrier frequency	2.3, 2.5, 3.3, 3.5 GHz	2.6 GHz specified to operate from 450 MHz to 2.6 GHz	3G bands
Bandwidth	5, 7, 8.75, 10 MHz	1MHz-20 MHz in steps of 180 KHz	5,10,20 MHz
Uplink multiple access DL access	OFDMA OFDM/TDM	SC-FDMA OFDM/TDM	OFDMA/CDMA OFDMA and CDMA are frequency multiplexed in UL. DL: OFDM/TDM
Sub carrier spacing	10.94 KHz	15 KHz	9.6 KHz
Super Frame – Frame – subframe - slot	Frame = 5 ms Ex: UL-subframe = 2.5 ms Ex: DL subframe = 2.5 ms	Frame = 10 ms Subframe = 1 ms [DL-UL] Subframe = 2 slots	Super frame = 25 ms Frame = 1 ms [DL-UL] Frame = 8 OFDMA symbols

Comparison Table

	WiMAX release1	LTE	UMB
Uplink Resource element	<p>Subcarriers are first divided in tiles. Each tile has four subcarriers over three OFDM symbols. Subcarriers are divided into 8 data and 4 pilot subcarriers. Tiles are re-numbered randomly and divided into six groups. Subchannel is formed by taking 6 tiles from the same group. Slot = 16 subcarriers x 3 OFDMA symbol</p>	<p>180 kHz x 1 ms 12 subcarriers x 8 OFDMA symbols</p>	FFS
Subchannel formation	Contiguous and diverse permutations	Contiguous blocks	FFS
BS scheduling//UL scheduling	CQI in UL through CQICH	Channel dependent scheduling: 1 ms resolution in time 180 KHz resolution in frequency UL: only contiguous blocks of frequency can be assigned in uplink [SC-FDMA] UL channel dependent scheduling is non-trivial	
AMC	<p>yes DL: QPSK, 16 QAM, 64 QAM UL: QPSK, 16 QAM</p>	<p>yes QPSK, 8PSK, 16 QAM, 64 QAM CQI in UL to support this.</p>	yes
UL power control	<p>Mandatory closed loop power control Optional open loop power control</p>	Closed loop and open loop power control	Closed loop power control

LTE Uplink SC-FDMA OFDMA with DFT pre-coding

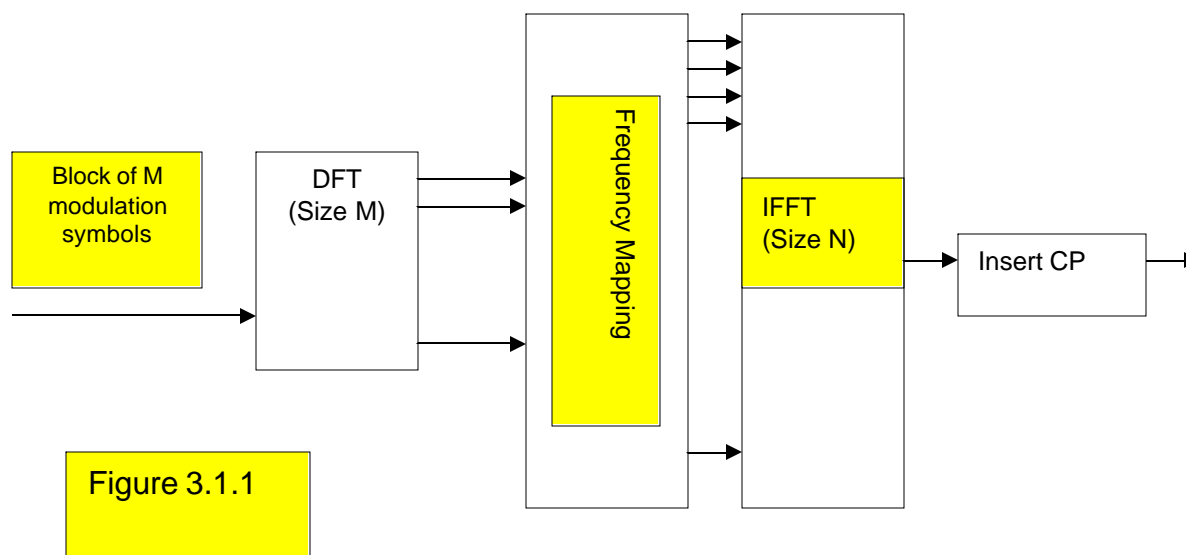

WiMAX base-band transmitter

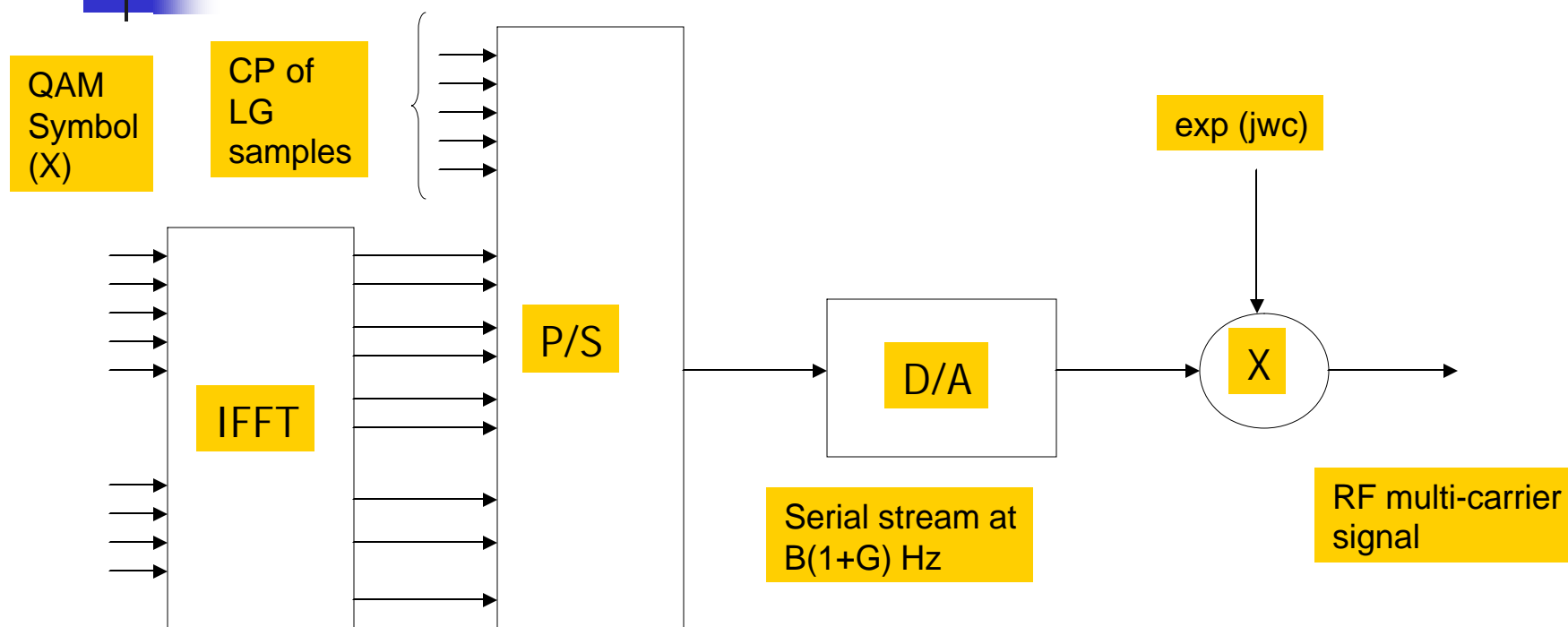

Speed = B/L Hz
 L Sub-carriers

Speed = B/L Hz
 $L(1+G)$ samples

UMB base-band transmitter

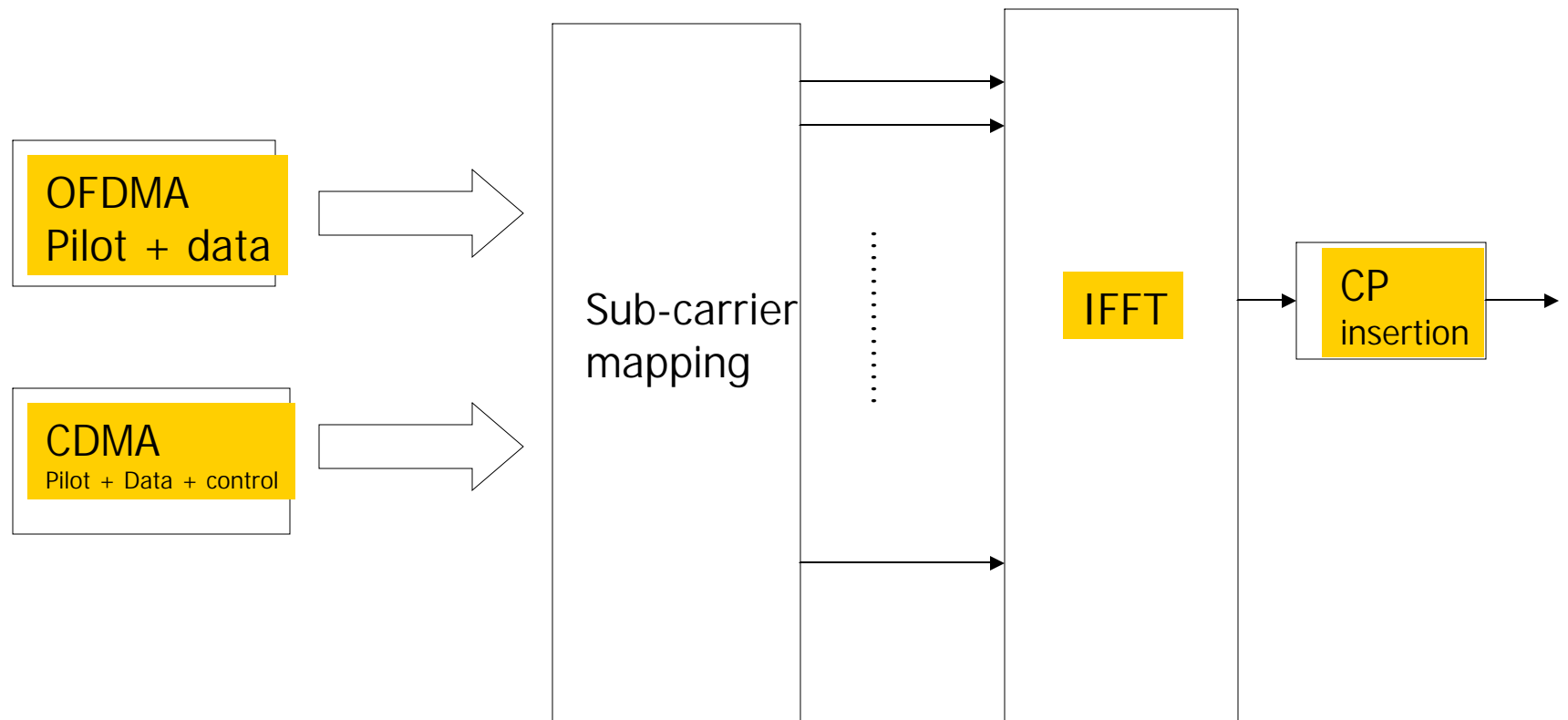

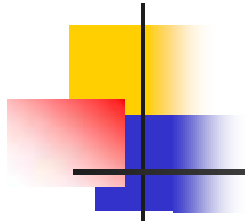

LTE UL OFDMA

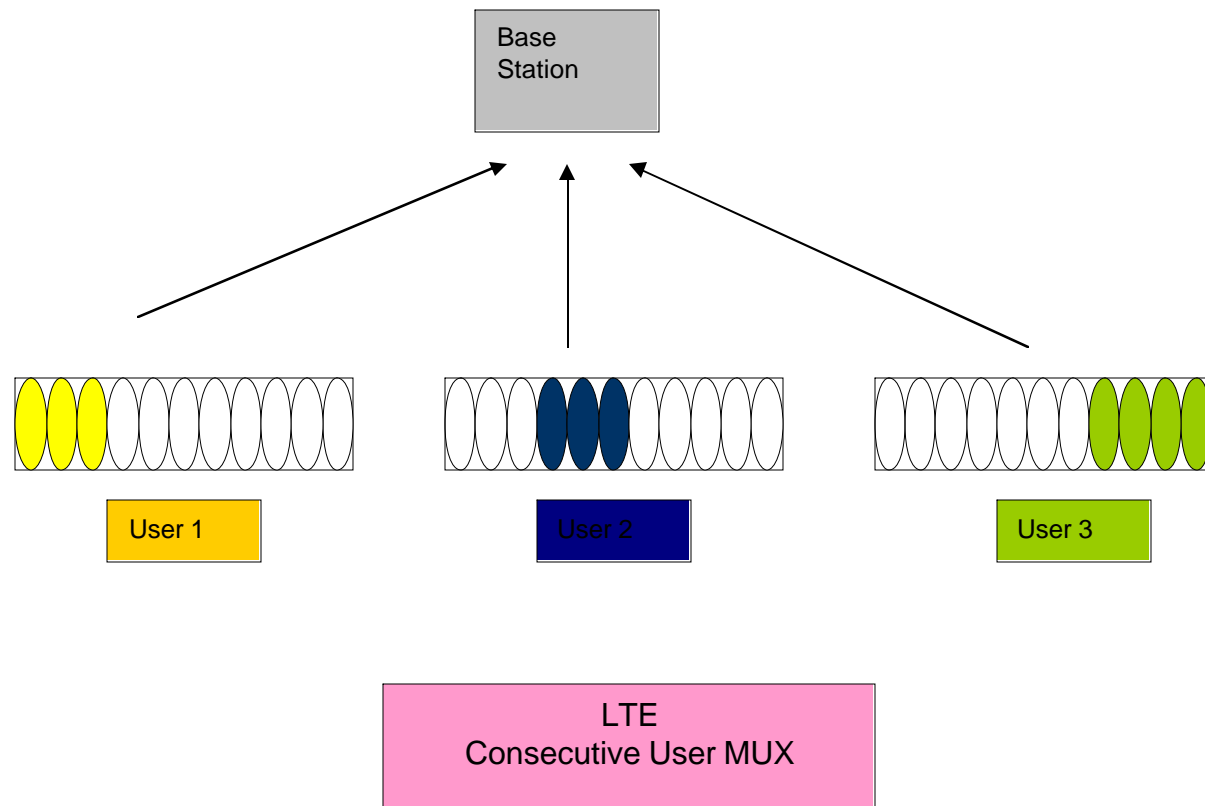

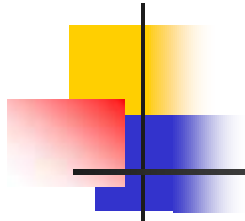

WiMAX UL OFDMA

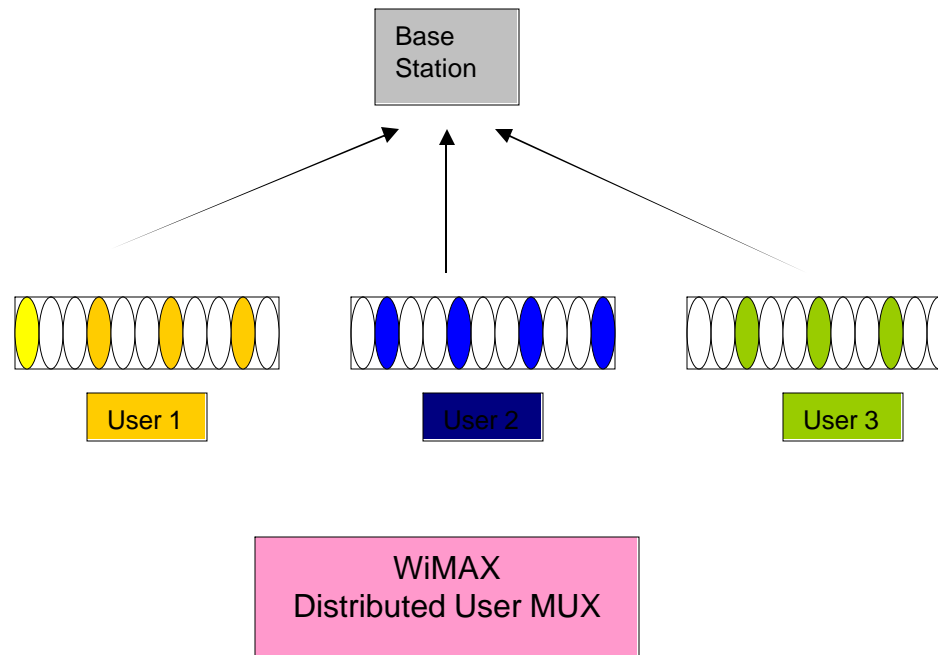

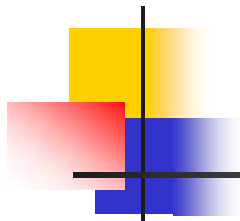

Conclusions

- The industry is transitioning from CDMA to OFDMA as the multiple access technology of choice.
- 2G was dominated by TDMA [1990-2000]
- 3G was dominated by CDMA [2000-2010]
- 4G is being dominated by OFDMA [2010-2020]